

VIDEOLOGIC **CONCEPT-K**

VCO-K

WHEEL ALIGNERS

True Italian Style.

WINDOWS 7



WIRELESS



CONTACT CLAMPS



USB



VCO-K.WINTRAX.VAPE

Cod. VZ97.002 - Edition 1 - February 2016

POWER
videologic



FASEP
MADE IN ITALY
SOMEONE YOU CAN TRUST

PERSONAL COMPUTER

Powerful personal computer located behind the monitor.

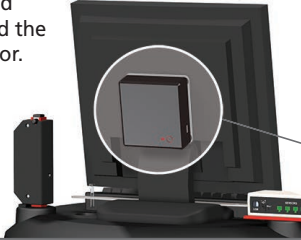

LCD SVGA 19" monitor.

USB interface.



Electronic track's gauge to enter exact vehicle's tracks automatically without any error.

CONSOLE

Console with monitor, mouse and keyboard at easy access for the user.

WINTRAX2

Infrared sensors combined with digital radio transmission and double inclinometer. Battery power reserve 30 hours.

REMOTE CONTROL

Infrared remote control to execute every function directly from the point of work.



PRINTER

A4 printer.

BATTERY CHARGER

Integrated battery charger.



VCO-K.WINTRAX.VAPE

Trolley on free wheels to be easily moved.



The new design of VCO-K shows the many changes in all technology behind it. The new style where everything you need has its own place: sensors stored on own battery charger, PC and printer well protected, clamps easily stored

away with extra adapters. A modern and elegant design to fit a unique mix of high-tech of a professional wheel aligner with a perfect Italian design.

The advantages of Fasep Measuring System



Reduced up to **80%** alignment preparation time

The fastest and most accurate wheel alignment!



Other alignment
4' 35"



FASEP
WINLOGIC



14/06/13 10:32

Customer: ACURA
Model: INTEGRA 3P

Wheel Base: 2560 mm
Front Track: 1475 mm
Rear Track: 1475 mm
Front/Rear Wheels Diameter: 14"

Front				Rear			
Min	Before	After	Max	Min	Before	After	Max
-1.0	-0.8	+0.1	+1.3	-1.0	-0.8	+0.1	+1.3
-1.9	-0.7	+0.1	+1.3	-1.9	-0.7	+0.1	+1.3
+0.5	+2.1	+2.1	+2.5	+0.5	+2.1	+2.1	+2.5
	+10*2	+2.5			+10*2	+2.5	
Total Toe (mm) Cross Camber Cross Caster				Total Toe (mm) Cross Camber Cross Caster			
Toe (mm) Camber Caster King Pin Included Angle Toe-Out at 20° Max Lock Angle, Internal Max Lock Angle, External				Toe (mm) Camber Caster King Pin Included Angle Toe-Out at 20° Max Lock Angle, Internal Max Lock Angle, External			



How much time have you got to waste today?

The advantages of Fasep Measuring System

Simple and friendly software.



Winlogic 3.0:

- Two simple buttons "Forward" and "Back"
- Friendly icons
- Winlogic Data Bank with over 32.000 models upgradable via internet
- USB port for communication with the PC

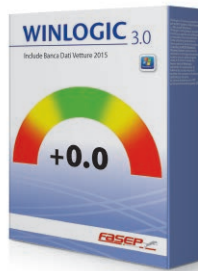

ATM SYSTEM

(Automatic Track Measurement)

OPTION

ATM measures front and rear track while car drives through.



It measures tracks in 5 seconds!

- NO use of electronic tracks gauge
- NO input width rim measure
- SI easy and fast operations
- SI Cars, vans and twin wheels

CONTACT CLAMPS

PATENTED

Great versatility: for each type of wheel!

Simple and safe use on each type of wheel.

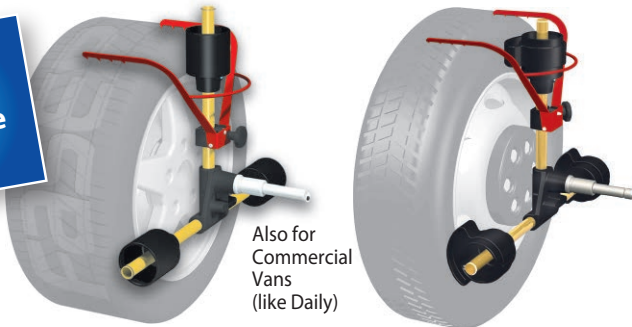

Also for Commercial Vans (like Daily)



- **DIRECTLY** applicable on tyres
- **NO** need to remove wheel cover
- **NO** need to compensate run-out
- **NO** adapters needed for different rim shapes



It ensures an exact measurement without need of run-out compensation, even if the rim is bent.

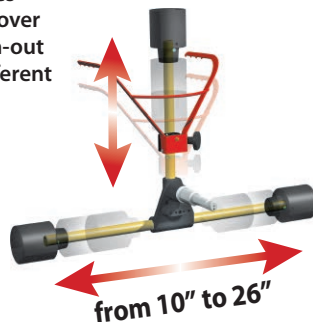

INFRARED CORDLESS SENSORS

Reading accuracy and speed of updating



WIN2
trax2
SENSOR

- Double inclinometer on chip
- 10 radio channels
- Weight: 750 gr
- Battery reserve: 30 hours



The advantages of Fasep Measuring System

With FASEP Measuring System measurement is always correct...

...even if sensor is not centered to tyre!

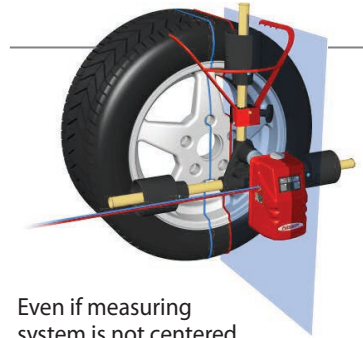
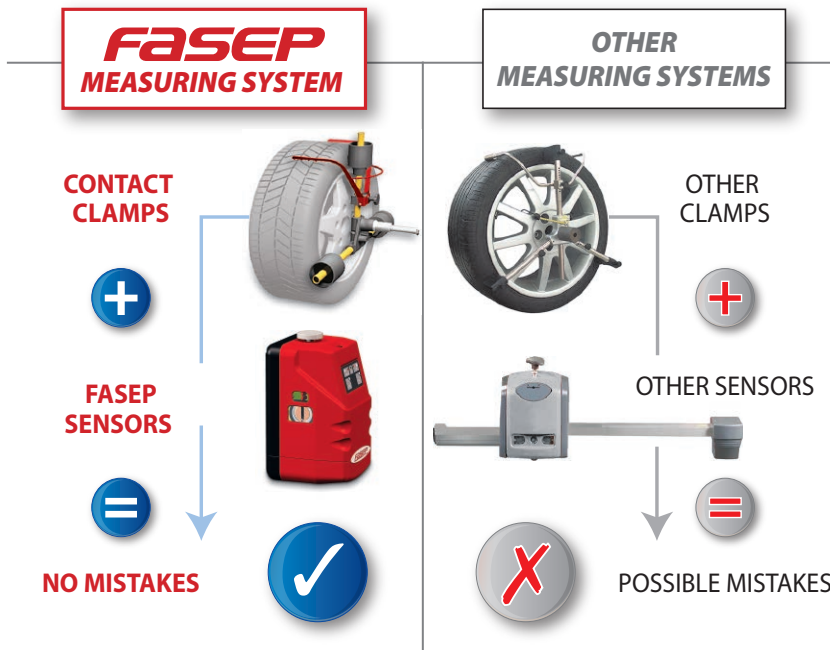

Even if measuring system is not centered to tyre, sensor is still correctly parallel to car.

Measurements are correct because FASEP sensors only measure along the car! (same as 3D systems!)



CONTACT CLAMPS: JUST INCOMPARABLE!

OTHER CLAMPS

FASEP CONTACT CLAMPS



They are mounted on the same way **both on high and low profile cars** because **they measure along the vehicle** and not across (left-right).



They directly touch on the tyre, no adapter for rim with limited edge is needed.

Run-out compensation is not needed

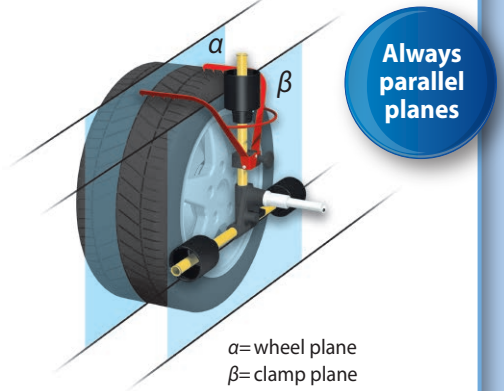

Always parallel planes

α = wheel plane
 β = clamp plane

STANDARD EQUIPMENT



POSSIBLE MEASUREMENTS

- Total toe
- Single toe RH and LH
- Thrust angle (automatic compensation)
- Camber
- Caster
- Caster Swing (selectable at 10 deg or 20 deg)
- "Live" Caster adjustment
- King-Pin (S.A.I.)
- Included Angle
- Multilink (Toe+Camber+Caster)
- Thrust Angle (only with electronic turntables)
- Run-Out compensation (single wheel, two wheels, four wheels, push-pull run-out)
- Toe-out-on-turns
- Set Back

MAIN FUNCTIONS

- Image bank
- Cars data bank
- Trucks data bank OPTION
- Customer data bank unlimited
- Zoom
- Printing
- Self calibration
- Self diagnostic
- Advanced diagnostics program
- Pre-inspection report
- Print-out format selection
- Resume function
- Ride-height related specifications
- Measure Suspension (Jack & Hold)
- Toe-curve (generic)
- Toe-curve (VAG)
- Engine-cradle adjustment
- Lifter compensation
- Steering at 10 deg
- Steering Wheel centering ⁽¹⁾

TECHNICAL FEATURES

• Power Source	200-240V 50-60Hz
• Power requirement	max 500 W
• Wheel Diameter	Cars 10-21" - Trucks 17-26"
• Measuring Accuracy	0,01° - 0,1mm
• MEASURING RANGE	(WINIRIS/WINTRAX)
• Total toe	±10°
• Single toe	±5°
• Camber	±12°
• Caster	±30°
• Lock angle	±40°
• Steering angle ⁽¹⁾	±80°
• Computer minimum equipment	Celeron
	4 GB Ram or higher
	800 MB available
	Windows 7
• Monitor	19" LCD
• External Interface	USB
• Languages	23
• Database	142 brands, over 9500 models
• Max Weight on Turntables	Standard 750kg
	Heavy Duty 1000kg
	Electronics 3500kg
• Battery charging time	10 hours
• Battery power reserve	30 hours

(1) electronics turntables required



A= 700 mm
 A1= 695 mm
 A2= 1230 mm
 B= 1450 mm
 B1= 1075 mm
 C= 760 mm
 C1= 1070 mm

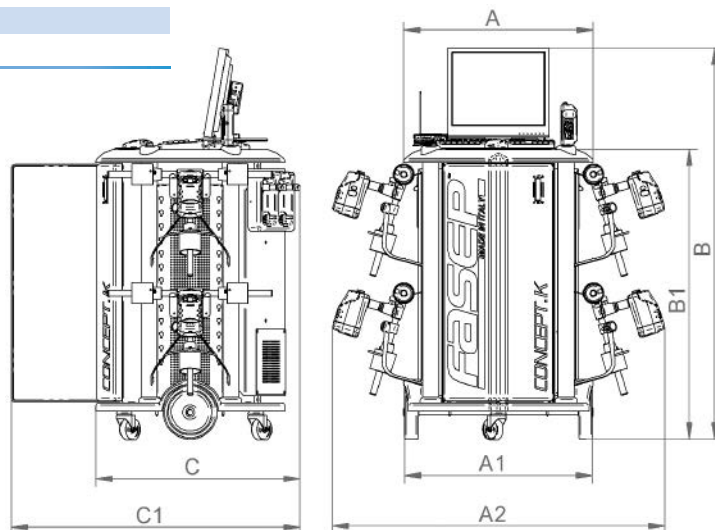

OPTIONAL EQUIPMENT

www.fasep.it

Authorized dealer



For further information about this and other products, please visit www.fasep.it

FASEP
 MADE IN ITALY

FASEP 2000 s.r.l.
 Via Faentina, 96 - 50032 Ronta (Firenze) ITALY
 Tel. +39 055 8403126 - Fax +39 055 8403354